



• Ham
1/8" (3.2 mm)
Dice

NEW!

AFFINITY® DICER

The new Affinity Dicer is the largest dicer Urschel manufactures and specializes in the cutting of difficult-to-cut meat products such as soft meats, cold temperature applications, or meats with high fat content. The machine accepts a large infeed product size of up to 10" (254 mm) in largest single product dimension. All transitional components work with the cutting elements to maintain positive advancement of the product throughout the cutting process - this is critical in difficult-to-cut applications. The rotating feed drum and feed roll are especially key in maintaining consistent, positive feeding into the dicing elements. Driven by a 25 HP gear motor with heavy duty gears and belts and equipped with a 5 HP VFD (variable frequency drive) motor on the crosscut, the Affinity excels at delivering maximum capacities. The 5 HP VFD motor allows significant savings by changing speeds instead of purchasing additional crosscut spindles. For ultimate sanitation, stainless steel contact surfaces on all components are polished to an Ra 32 finish. The Affinity delivers precise dices on such meat products such as beef/chicken logs, pepperoni, ham, and salami.

The Affinity is manufactured in two different models — standard [A] and with a built-in conveyor [B]. The built-in conveyor model offers a built-in conveyor feed chute to optimize feeding. The Affinity accepts a wide range of infeed products in different shapes and sizes. The standard Affinity accepts product infeed up to 7" (178 mm) maximum. The Affinity with conveyor feed chute accepts maximum infeed of blocks up to 7" (178 mm) or up to 10" (254 mm) maximum in largest single dimension depending on the product.

TYPES OF CUTS

SLICE THICKNESS: 1/8 to 3/4" (3.2 to 19.1 mm)

DICES: A slicing knife, circular knife spindle, and crosscut knife spindle are used for dicing.

Changing the dice size is done by adjusting slice thickness, variable frequency drive, and cutting spindles as needed.

- Circular Knife Spindle: 1/8 to 2" (3.2 to 50.8 mm)
- Crosscut Knife Spindle: 1/8 to 2" (3.2 to 50.8 mm)

STRIP CUTS: Flat strips can be made by removing either the crosscut knife spindle or the circular knife spindle. Combinations of circular knives or crosscut knives can be used to shorten the length of the strips.

- 1/8 to 2" (3.2 to 50.8 mm) in length

CUTTING OVERVIEW

1. Impeller paddles
2. Slicing Knife
3. Adjustable Slice Gate
4. Rotating Feed Drum
5. Feed Roll
6. Circular Knives
7. Crosscut Knives
8. Stripper Plate

• Salami
1/8 x 1 x 1/8"
(3.2 x 25.4 x
3.2 mm) Strips



• Extruded Pet Food
1/4 x 1/4 x 1/2"
(6.4 x 6.4 x 12.7 mm)
Dices



SPECIFICATIONS

AFFINITY [A]

Length: 64.92" (1649 mm)
Width: 62.52" (1588 mm)
Height: 69.46" (1764 mm)
Net Weight: 2800 lb
(1270 kg)
Motors: 5 HP (3.6 kW)
25 HP (18 kW)

AFFINITY [B]

with conveyor feed chute
Length: 71.46" (1815 mm)
Width: 62.52" (1588 mm)
Height: 69.45" (1764 mm)
Net Weight: 2800 lb
(1270 kg)
Motors: 5 HP (3.6 kW)
25 HP (18 kW)

SPECIFICATIONS

Length: 64.07" (1627 mm)
Width: *63.62" (1616 mm)
Height: 68.44" (1738 mm)
Net Weight: 1500 lb (680 kg)
Motor: 5 or 10 HP (3.7 or 7.5 kW)

*Various discharge chutes are available. Machine width varies depending on style of discharge chute. Width listed is the maximum machine width available.

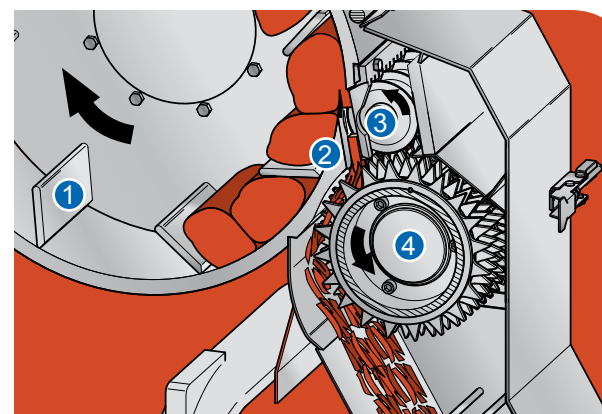

SHREDDING OVERVIEW

1. Impeller Paddles
2. Slicing Knife
3. Circular Knives
4. Shredding Discs

• Preformed Turkey Roast
1/4 x 1/4" (6.4 x 6.4 mm) x
various length Strips



DICING OVERVIEW

1. Impeller Paddles
2. Slicing Knife
3. Circular Knives
4. Crosscut Knives

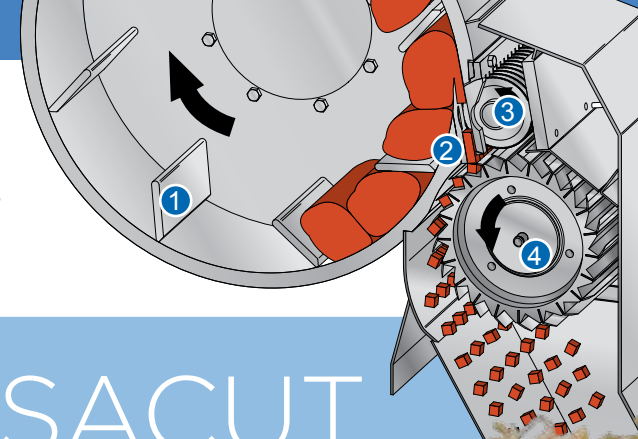

NEW!

DIVERSACUT™ 2110A™ DICER

The largest machine in the DiversaCut line, the *DiversaCut 2110A™ Dicer produces dices, strips, slices, and shreds at high production capacities. With a maximum infeed of 10" (254 mm) in any dimension, the machine offers cost-savings by eliminating the need to pre-cut product. This new dicer promotes more precise cut tolerances with slice adjustment and lockdown features. The machine also features fine-tuning through adjustable collars on both cutting spindles for ultimate precision.

TYPES OF CUTS

STRIP CUTS: Flat and crinkle strip cuts in a variety of widths can be made by removing either the crosscut knife spindle or the circular knife spindle assembly.

Minimum flat strips such as 1/8 x 1/8" x length of product (3.2 x 3.2 mm x length of product); crinkle strips such as 9/32 x 9/32" x length of product (7.1 x 7.1 mm x length of product); Maximum flat strips such as 1 x 1" x length of product (25.4 x 25.4 mm x length of product); crinkle strips such as 5/8 x 5/8" x length of product (15.9 x 15.9 mm x length of product). Note: Combinations of circular knives or crosscut knives can be used to shorten length of strips.

DICES: A slicing knife, circular knife spindle, and crosscut knife spindle are used for dicing. Changing the dice size is done by using the required cutting spindles and adjusting the slice thickness.

- **Circular knife cuts:** 1/8 to 3" (3.2 to 76.2 mm)
- **Crosscut knife cuts:** 3/32 to 2-1/2" (2.4 to 63.5 mm)
- **Crosscut knife crinkle cuts:** 9/32 to 5/8" (7.1 to 15.9 mm)

SHREDS: Fine, medium, and coarse shreds can be produced on hot or chilled cooked meat products.

• Pepperoni
1/4" (6.4 mm) Dice
• Frozen Tempered
Beef 3/4"
(19.1 mm) Dice



• Cooked
Turkey Breast
Short Shreds

• Frozen Tempered
Salmon
3/4" (19.1 mm)



MODEL M6

The patented Model M6 is a versatile, two-dimensional cutting machine designed for dicing, strip cutting, or shredding a variety of products through a wide range of sizes. Ideally suited for cutting frozen-tempered, fresh-chilled, or hot cooked beef, poultry, or pork. The machine operates continuously at high production capacities and is designed for easy cleanup and maintenance.

THE MODEL M6 OFFERS:

- Hinged access panels promote sanitation and ease of maintenance.
- Solid bar and angle frame design.
- Integrated electrical enclosure with a convenient operator stop/start station.
- Maximum versatility available through different cutting/shredding options.
- Wide range of dice sizes from 3/16 to 1-1/2" (4.8 to 38.1 mm).
- Maximum infeed thickness of 1" (25.4 mm).
- Special feed discs or blunt crosscut knives offer shred configurations for wide varieties of hand-pulled looking shreds.
 - Available with VFD (variable frequency drive) or across-the-line starting.
 - All grease fittings are easily accessible on the exterior of the machine to facilitate maintenance.
 - Overall stainless steel design including motor.

• • • • • Beef Jerky
1-1/8 x 1-7/8"
(28.6 x 47.6 mm)
Pieces

• • • • • Frozen-tempered Chicken Breast
3/8 x 3/8" (9.5 x 9.5 mm) x
input thickness of product

• • • • • Frozen-tempered Fish
3/4 x 3/4" (19.1 x 19.1 mm) x
input thickness of product

• • • • • Frozen-tempered Bacon
1 x 1" (25.4 x 25.4 mm) x
input thickness of product

SPECIFICATIONS

- **Length:** 119.03" (3023 mm)
- **Width:** 33.48" (850 mm)
- **Height:** 50.37" (1280 mm)
- **Net Weight:** 1640 lb (745 kg)
- **Motor:** 5 or 7.5 HP (3.7 or 5.6 kW)

• • • • • Frozen-tempered Beef Brisket
1 x 1" (25.4 x 25.4 mm) x
input thickness of product

The Urschel Model M6's hinged access panels and solid bar/angled framed design promote sanitation and ease of maintenance.

TYPES OF CUTS

DICES: Many sizes of cuts are possible by combining the various selections of circular knife spacings with different crosscut knife spindles.

- Circular knives: 3/16 to 1-1/2" (4.8 to 38.1 mm)
- Crosscut knives: 1/8 to 5.66" (3.2 to 144 mm)

STRIP CUTS: Strip cuts can be made by removing the crosscut knife spindle from the machine. The length and thickness of the strips will depend upon the size of the original product.

SHREDS: Feed discs work together with special shredding discs or blunt knives to produce a wide variety of shred consistencies from coarse to fine. Various shred lengths are also possible depending upon set-up.

• • • • • Ham
3/8" (9.5 mm) Strips

• • • • • Cooked Pork
• Medium, Long
• Shred

• • • • • Cooked Chicken Breast
1 x 1" (25.4 x 25.4 mm) x input
thickness of product

CUTTING OVERVIEW

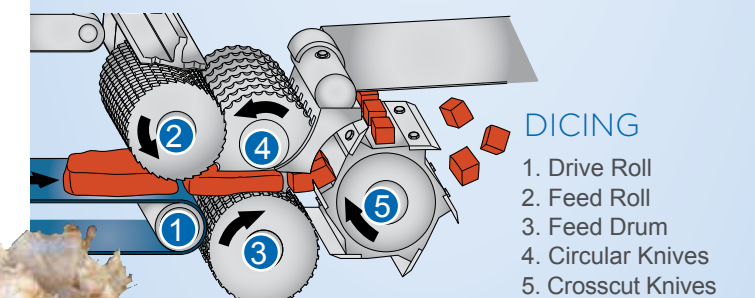
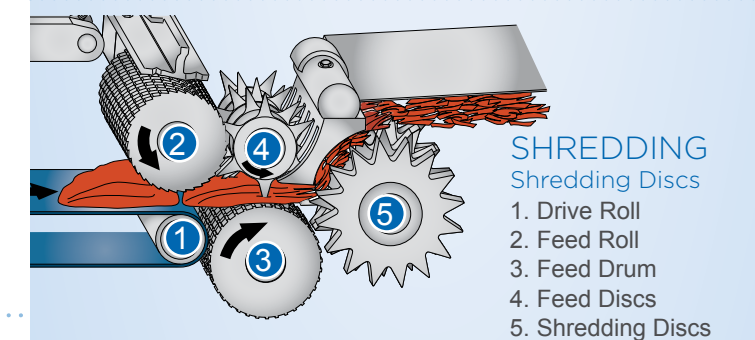
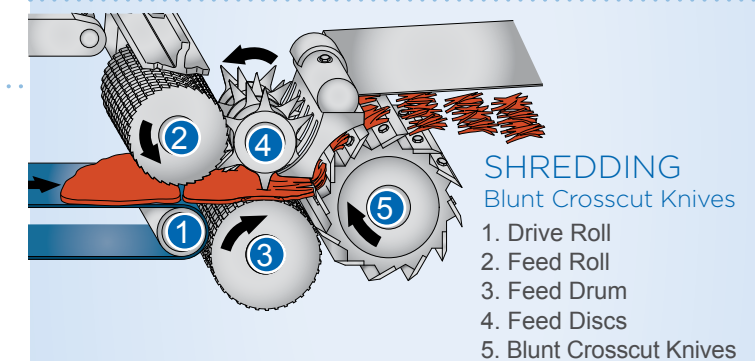
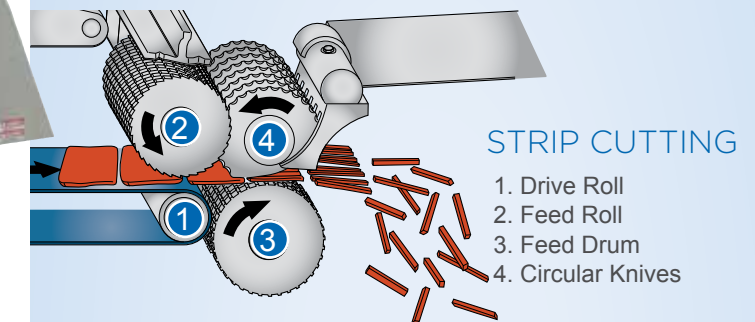

The Urschel Model M6's hinged belt guards simplify servicing and changing of feed belts. Feed belt tension is easily set by turning one nut [A] on the exterior of the machine.

The Urschel Model M6 feed belt view offers a stainless steel motor [B], an integrated electrical enclosure [C] incorporated with a convenient operator stop/start station [D].

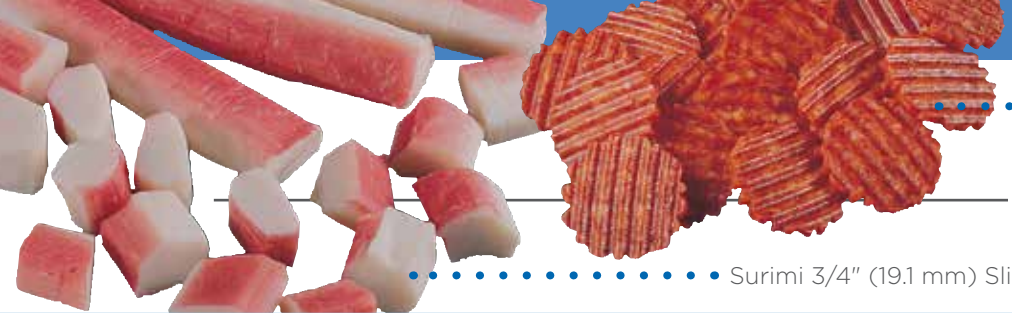

Surimi 3/4" (19.1 mm) Slice

Pepperoni without peppercorns 1/8" (3.2 mm) Crinkle Slice with Optional Power Hold-Down Belt

E TRANSLICER® CUTTER

The patented E TranSlicer® Cutter uniformly slices a wide variety of products including cooked and processed meats and various food products.

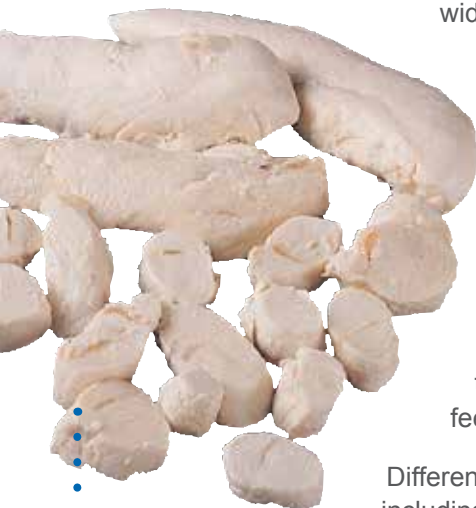

Cooked Chicken Tenders 1/2" (12.7 mm) Slice

The cutter is ideally suited for elongated products. Maximum product infeed of firm products is 4" (101.6 mm) in diameter. The E TranSlicer Cutter features continuous operation for uninterrupted production. Hinged and sliding access panels promote easy cleanup and routine maintenance. Also, an optional hold-down top belt is available for additional positive feeding assistance.

Different styles of cutting wheels are available, including the slicing wheel and the patented MicroSlice® Wheel. Of the two wheels, the slicing wheel is currently the most widely used in the meat industry. For processors seeking thinner slices, the patented MicroSlice Wheel is also an option. This wheel offers inexpensive, cost-saving knives which are easily replaceable. Meat processors who also process other types of products may find the other cutting wheels a valuable option.

Chicken Wieners 7/16" (11.1 mm) Slice with Optional Power Hold-Down Belt

CUTTING OVERVIEW

1. Feed Belt
2. Slicing Wheel
3. Slicing Knives

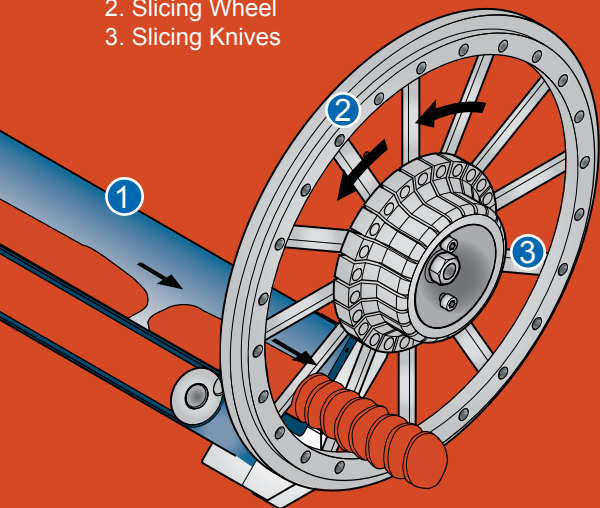

SPECIFICATIONS

Length: 100.78" (2560 mm)
117.26" (2978 mm) with prep table
Width: 35.31" (897 mm)
Height: 61.79" (1569 mm)
66.36" (1686 mm) with prep table
Net Weight: 1328 lb (600 kg)
Motor: 3 HP (2.2 kW)
Feed Belt Motor: 1 HP (.75 kW)

TYPES OF CUTS

SLICING WHEEL: [A]

Straight or crinkle slices: 1/32 to 2" (.8 to 50.8 mm)

MICROSLICE WHEEL: [B]

Flat slices: .030 to .240" (.8 to 6 mm)

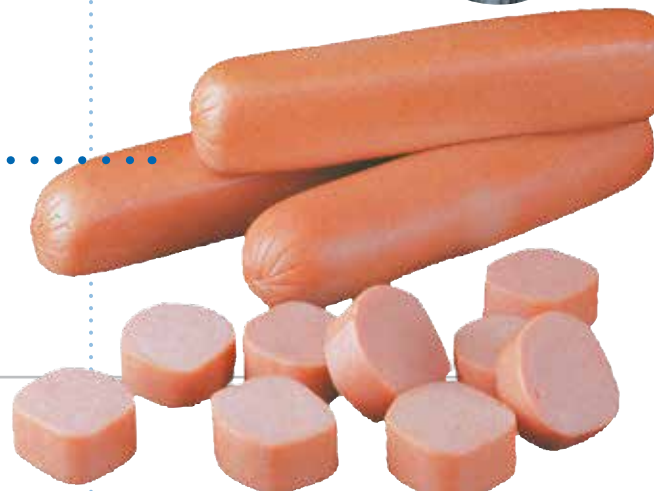

Cooked Bacon Strips 1/8 x 3/8" (3.2 x 9.5 mm) x input thickness of product



MODEL J9-A

The Model J9-A uniformly dices or strip cuts cooked or frozen-tempered meats at high production capacities with a minimum of fines. Dices of 3/16 to 1-1/2" (4.8 to 38.1 mm) are cut from firm products up to 3/8" (9.5 mm) in thickness including beef, veal, poultry, pork, or fish. The Model J9-A features continuous operation for uninterrupted production, and simplified design for easy cleanup and maintenance.

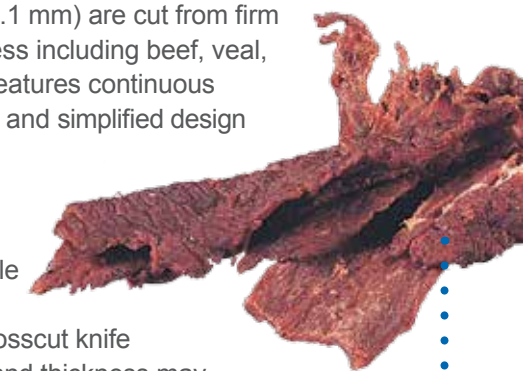

Beef Jerky 3/4 x 1-1/4" (19.1 x 31.8 mm) x input thickness of product

SPECIFICATIONS

Length: 99.08" (2517 mm) **Net Weight:** 930 lb (420 kg)
Width: 44.34" (1126 mm) **Motor:** 5 HP (3.7 kW)
Height: 61.92" (1573 mm)

CUTTING OVERVIEW

1. Feed Belt
2. Drive Rolls
3. Feed Roll
4. Circular Knives
5. Crosscut Knives

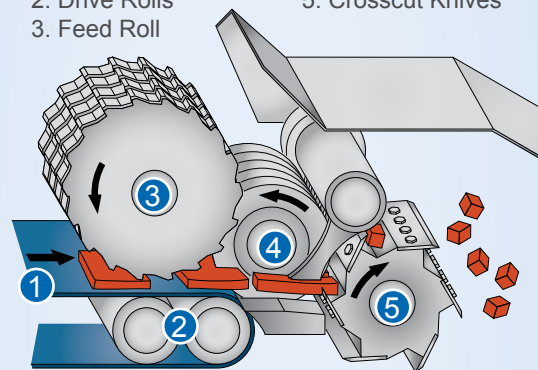

TYPES OF CUTS

DICES: Many sizes of cuts are possible by combining the various selections of circular knife spacings with different crosscut knife spindles. Product structure, firmness, and thickness may cause a variation in the size of cut. Thickness of dices will be the thickness of the product fed into the machine.

- Circular knives: 3/16 to 3" (4.8 to 76.2 mm)
- Crosscut knives: 3/16 to 3" (4.8 to 76.2 mm)

STRIP CUTS: Strip cut length can be controlled by using various crosscut knife selections. Strip cuts can also be made by removing the crosscut knife spindle from the machine. The length and thickness of the strips will depend upon the size of the original product.

SPECIFICATIONS

Length: 46.11" (1171 mm)
Width: 36.93" (938 mm)
Height: 71.39" (1833 mm)
Net Weight: 700 lb (320 kg)
Motor: 5 HP (3.7 kW)

CUTTING OVERVIEW

1. Impeller Paddles
2. Slicing Knife
3. Rotating Feed Drum
4. Feed Spindle
5. Circular Knives
6. Crosscut Spindle
7. Stripper Plate

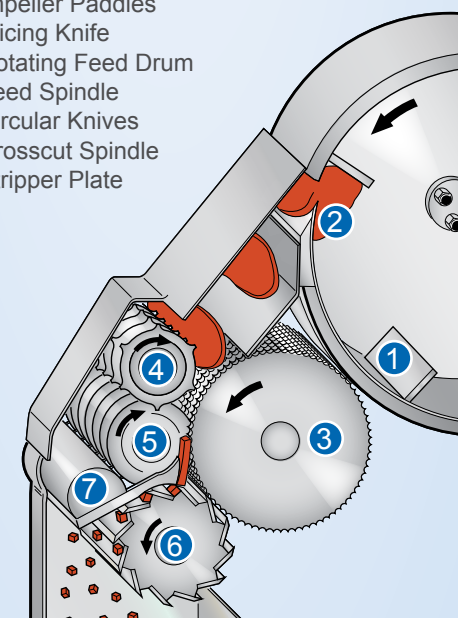

MODEL RA-A

The Model RA-A dices or strip cuts chunks of processed meats. Maximum infeed size is 3-1/2" (88.9 mm) in any dimension. Ideal machine for meat processors that also cut various vegetables to produce small to intermediate dices and strip cuts. Urschel also offers the Model RA-HD, a heavy duty dicer that features a 10 HP motor.

Both models feature continuous operation for uninterrupted production, and simplified design for easy cleanup and maintenance.

TYPES OF CUTS

SLICES: 1/16 to 3/8" (1.6 to 9.5 mm)

DICES: Many cut sizes are possible by combining various selections of circular knife spacings with different crosscut knife spindles.

- Circular knives: 1/8 to 1" (3.2 to 25.4 mm)
- Crosscut knives: .05 to 3" (1.3 to 76.2 mm)

STRIP CUTS: Strip cuts can be made by removing the crosscut knife spindle from the machine. The length and thickness of the strips will depend upon the size of the original product.

Cooked Ham 1/8 x 1/8 x 1" (3.2 x 3.2 x 25.4 mm)

Hard Salami 3/8" (9.5 mm) Dice





- (Left to Right)
- Restructured Steak, Model 5600 3J-030510 Cutting Head
- Baby Food, Model 9300 2341569-(.25) Microcut Head
- Breaded Chicken Patties, Model 5600, 3J-030510 Cutting Head



Model 1700

COMITROL® PROCESSORS



Model 2100

COMMINATION

Comminution is the process of reducing a product to a smaller size. Conventional methods of comminution employ some type of grinding, smashing, or tearing action which can produce excessive heat and degrade the quality of the finished product. This can also generate a higher percentage of final product which fall outside the desired targeted size and negatively impact the yield.

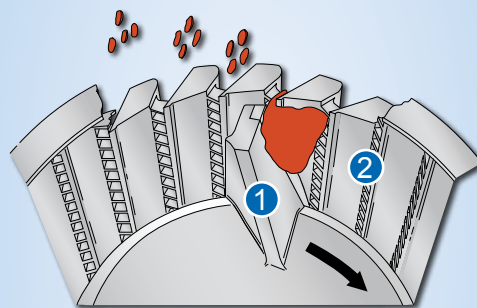

Cutting Head

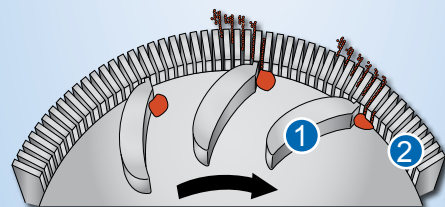

Microcut Head

CUTTING OVERVIEW

1. Impeller Paddles
2. Cutting Blades



Model 3600 Slant

CONTROLLED COMMINATION

The word "Comitrol" means controlled comminution. The **Comitrol®** Processor line uses the principle of incremental shear to ensure highly efficient comminution by rotating the product inside a stationary reduction head at high rotational speeds. In addition, continuous single pass operation achieves consistently uniform output product size reduction at high capacities.



Model 5600

COMITROL VERSATILITY

Several different Comitrol Processor machines are available to suit your application along with different, easily interchangeable cutting heads. A no-cost, no-obligation test is recommended to determine the best Comitrol set-up. Notify your local Urschel sales representative for more information.

Standard Comitrol operations regarding fresh to frozen meats include:

- Shred beef for barbecued meat products
- Flake cut poultry in cooked ham products
- Produce a meat slurry for use in nutritional supplements
- Comminute beef, fat, and pork rind for sausage production
- Reduction of gristle and connective tissue into minute sizes for fabricated meat products
- Reduce meat into a smooth, uniform consistency for use in gravies and sauces
- Emulsify pork for sausage and sandwich meats
- Comminute beef, fish, and poultry for use in pet foods



Model 9300 Model 9300 with Feeder



URSCHEL

The Global Leader in Food Cutting Technology
www.urschel.com | info@urschel.com

L2681 | JULY 2014 | (s.s. L2546)

YOU ARE INVITED TO TEST CUT YOUR PRODUCT

Urschel Laboratories has a complete network of test facilities and experienced service and sales representatives around the world ready to work for you on any size reduction application. Contact your local Urschel Laboratories' representative to schedule a comprehensive, no-obligation test cut today at www.urschel.com

® DiversaCut, DiversaCut 2110, Urschel, Comitrol, TranSlicer, and MicroSlice are registered trademarks of Urschel Laboratories, Inc. ™ DiversaCut 2110A trademark pending. [®] The Model M6 may contain parts protected by U.S. Patent No. 5722143 and EP0892697. * The DiversaCut 2110A Dicer may contain parts protected by U.S. Patent No. 6883411, and European Patent No. EP1377415. ^{††} The E TranSlicer may contain parts protected by U.S. Patent Nos. 5992284, 6148702, 6148709, 7178440, 7721637, 5896801, 6460444, 6792841, 6920813, and EP1042107. [®] MicroSlice may contain parts protected by U.S. Patent No. 5992284 and EP1042107. ^{**} The Comitrol Processor may contain parts protected by U.S. Patent No. 5201469.